

# CMG



## *MATRIX X* *USER'S MANUAL*



Version 1.0

**Trademarks:**

CME and Matrix X are the registered trademarks of Central Music Co. All the other trademarks belong to their respective owners.

**FCC INFORMATION (U.S.A)**

1. **IMPORTANT NOTICE: DO NOT MODIFY THIS UNIT!**  
This product, when installed as indicated in the instructions contained in this manual, meets FCC requirements. Modifications not expressly approved by CME may void your authority, granted by the FCC, to use the product.
2. **IMPORTANT:** When connecting this product to accessories and/or another product use only high quality shielded cables. Cable(s) supplied with this product **MUST** be used. Follow all installation instructions. Failure to follow instructions could void your FCC authorization to use this product in the USA.
3. **NOTE:** This product has been tested and found to comply with the limits for a Class B Digital device, pursuant to Part 15 of the FCC Rules. These limits are designed to provide reasonable protection against harmful interference in a residential environment. This equipment generates, uses and can radiate radio frequency energy and, if not installed and used according to the instructions found in the users manual, may cause interference harmful to the operation of other electronic devices. Compliance with FCC regulations does not guarantee that interference will not occur in all installations. If this product is found to be the source of interference, which can be determined by turning the unit "OFF" and "ON", please try to eliminate the problems by using one of the following measures:

Relocate either this product or the device that is being affected by the interference.

Utilize power outlets that are on different branch (circuit breaker or fuse) circuits or install AC line filter(s).

In the case of radio or TV interference, relocate/reorient the antenna. If the antenna lead-in is 300 ohm ribbon lead, change the lead-in to co-axial type cable.

If these corrective measures do not produce satisfactory results, please contact the local retailer authorized to distribute this type of product. If you cannot locate the appropriate retailer, please contact CME.

The above statements apply **ONLY** to those products distributed in the USA.

---

## **CONTENTS**

<b>FCC INFORMATION (U.S.A)</b> .....	<b>2</b>
<b>Introducing the Matrix X</b> .....	<b>4</b>
<b>Front Panel</b> .....	<b>5</b>
<b>Rear Panel</b> .....	<b>6</b>
<b>Connection examples</b> .....	<b>8</b>
Connection examples of front panel.....	8
Connection examples of rear panel.....	9
Signal flow chart (block diagram).....	9
<b>Examples of Matrix X usage</b> .....	<b>10</b>
<b>1. Stand-alone Mode</b> .....	<b>10</b>
A. Connecting to a synthesizer or electric piano for live performance.....	10
B. Listen to music.....	10
C. Practice or play Electric Guitar / Bass along with music.....	11
D. Vocal Practice and Karaoke.....	11
<b>2. Working together with sound card</b> .....	<b>12</b>
A. Recording from the Line In.....	12
B. Recording from a microphone.....	12
C. Recording an Electric guitar (or bass).....	13
<b>Matrix X setting chart</b> .....	<b>14</b>
<b>Specifications</b> .....	<b>14</b>
<b>Matrix X Technical information</b> .....	<b>15</b>

---

## **INTRODUCING THE MATRIX X**

The Matrix X is a small, multi-function, professional audio system, which integrates a microphone pre-amplifier with +48V phantom power, a Direct Box for connecting a guitar or bass, a 5-channel dual bus stereo mixer and dual headphone amplifiers. The unique dual bus design makes Matrix X the best choice for use with a computer based hard-disk recording system or when you want to add a microphone to a digital instrument with line in and line outs. For example, use the Matrix X with a synthesizer with a sampling function or to add vocals to a digital piano with line inputs and outputs.

Using the Matrix X with a Sound card or simple computer USB Audio I/O

After connecting Matrix X to your sound card or I/O, your new music-making system will include many practical and convenient functions. Matrix X features not only inputs and outputs for transmitting signal to/from sound card but also two headphone outputs with independent volume control knobs for different monitoring needs. Matrix X also features different connectors such as Line In, Monitor Output, gain adjustable Mic In and Guitar In to satisfy all of your music-making needs. In addition, the Line In of Matrix X can receive un-balanced signals and convert into balanced signals. Furthermore, Matrix X provides +48V phantom power to support professional microphones.

Hardware Direct Monitor is another advantage for Matrix X users. Signals from the Line In, Mic In or Guitar In can be sent to the headphone outputs or monitor speakers directly by pressing the Direct Monitor button. Un-pressing the button will route those signals to the input of the sound card then out to the sound card's output and through Matrix X back to the headphone output or monitor speakers. This is a convenient function to compare the sound before and after processing and recording on the computer.

Besides working with a sound card, Matrix X can be used as a stand-alone device to add a microphone or guitar to a keyboard that has a line in and out. Simply connect the audio matrix and you can easily add a microphone or guitar to a digital piano with speakers or increase in the number of headphone outputs. Matrix X is a unique utility mixer that fits many different audio applications because of its flexible and powerful design. It's especially useful in a small computer recording environment. You'll find that Matrix X will come in handy for many different situations and that it's quality and cost performance is outstanding.

## FRONT PANEL

Matrix X front panel has all of the input gain and output volume control knobs, and the switches for direct monitor, phantom power and guitar signal. Below is the detail of Matrix X front panel.

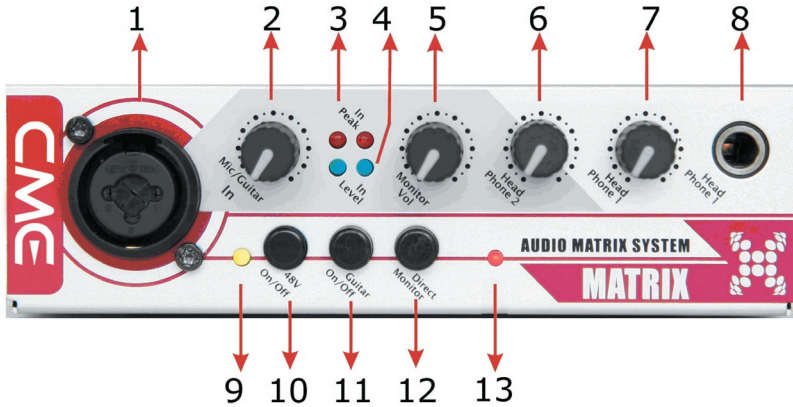

### 1. **XLR / TS combo connector**

You can connect a microphone or electrical guitar here. The XLR input is balanced and provides 48V phantom power (by pressing the “48V On / Off” button). It is suitable for professional condenser microphones. The  $\frac{1}{4}$ ” connector is un-balanced and is suitable for dynamic coiled microphone and electric guitar or bass.

### 2. **Mic / Guitar In**

Adjusts the gain of the signal from the combo connector

### 3. **In Peak**

A red LED flashes when the input signal level is near distortion indicating it would be better to lower the input gain.

### 4. **In Level**

A blue LED will light up and flash if signal is available at the input channel

### 5. **Monitor Vol**

Adjusts the volume level of the Monitor Output

### 6. **Head Phone 2**

Adjusts the volume level of Head Phone 2

### 7. **Head Phone 1**

Adjusts the volume level of Head Phone 1

### 8. **Head Phone 1**

The first headphone output connector (stereo)

### 9. Phantom power LED

This LED will light up when phantom power supply is turned on and is providing power to XLR input

### 10. 48V On / Off

Switches the phantom power on or off. Turn phantom power on by pressing the button.

### 11. Guitar On / Off

Pressing this button will activate the TS connector of the combo connector to receive external signals.

### 12. Direct Monitor

Switches the direct monitor function On or Off. Pressing this button down, all of the input signals will be sent to Head Phone 1 / 2 and Monitor Output directly. If you are using recording software to record, you should un-press this button to avoid latency while monitoring.

### 13. Power LED

This LED will light up when trun on the power of Matrix X.

## REAR PANEL

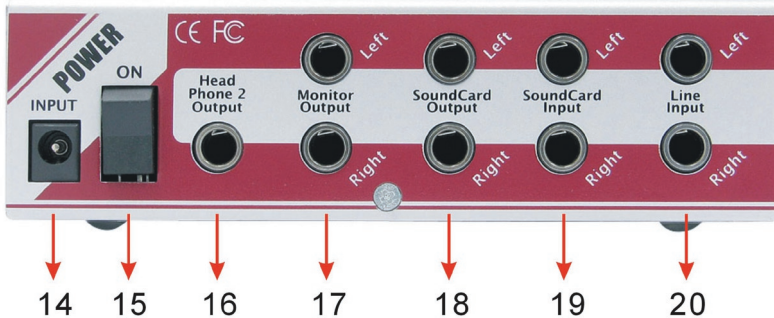

The main input and output connectors are in rear panel of Matrix X.

### 14. Power Input

Plug the bundled power adapter here for supplying power to the Matrix X .

To avoid voiding your warranty, only use the power adapter supplied for use with Matrix X.

### 15. Power On

Power switch.

### 16. Head Phone 2 Output

The second headphone output connector (stereo)

---

### **17. Monitor Output**

Signal monitor output connectors, the left channel is on the top, the right channel is on the bottom. Both of the two connectors are balanced 1/4" TRS jacks.

### **18. Sound Card Output**

These are stereo outputs of Matrix X. Please connect here to the Line In of your sound card or the Aux In of an external device. These jacks could be used as auxiliary outputs as well. The Left channel is on the top and the Right channel is on the bottom. Both of the two connectors are balanced 1/4" TRS jacks.

### **19. Sound Card Input**

These are stereo inputs to Matrix X. Please connect sound card's Line Out or the Line Out of an external device to here. These jacks could be used as auxiliary inputs as well. The Left channel is on the top and the Right channel is on the bottom. Both of the two connectors are balanced 1/4" TRS jacks.

### **20. Line Input**

External devices connect to these jacks to transmit analog signals into Matrix X. The Left channel is on the top and the Right channel is on the bottom. Both of the two connectors are balanced 1/4" TRS jack. The unbalanced signals go into Matrix X from here can be converted into balanced signals to prevent noise interference.

---

## CONNECTION EXAMPLES

The Matrix X is a very flexible device that features many input and output connectors for different usage and applications. You can connect various external equipment to meet your audio needs.

### Connection examples of front panel

Note: You can only connect ONE device to the XLR / TS combo connector at the same time, either an XLR microphone or TS E.guitar/bass. The fig. Shows that the XLR / TS combo connector can be used to connect XLR microphones, as well as TS E.guitar/bass, but you cannot connect XLR device and TS device at the same time.

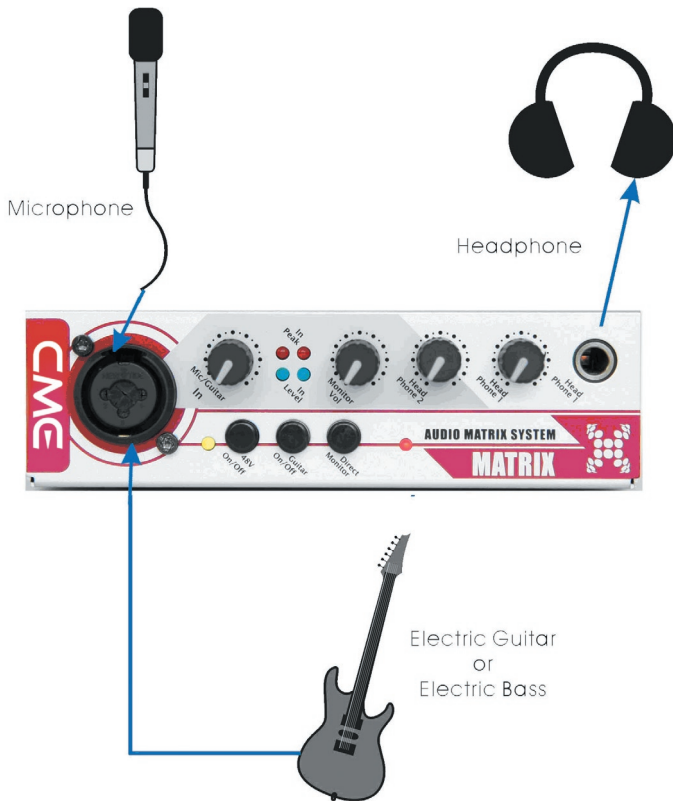



## Connection examples of rear panel

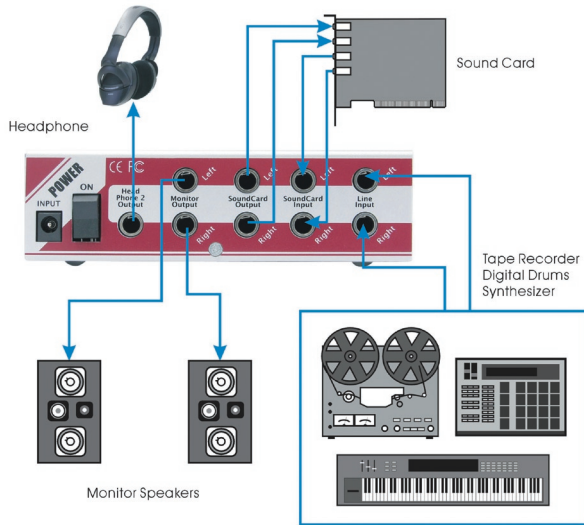

## Signal flow chart (block diagram)

The flow chart below shows how signals are routed through the Matrix X, which may help you better understand how to use the Maxtrix X.

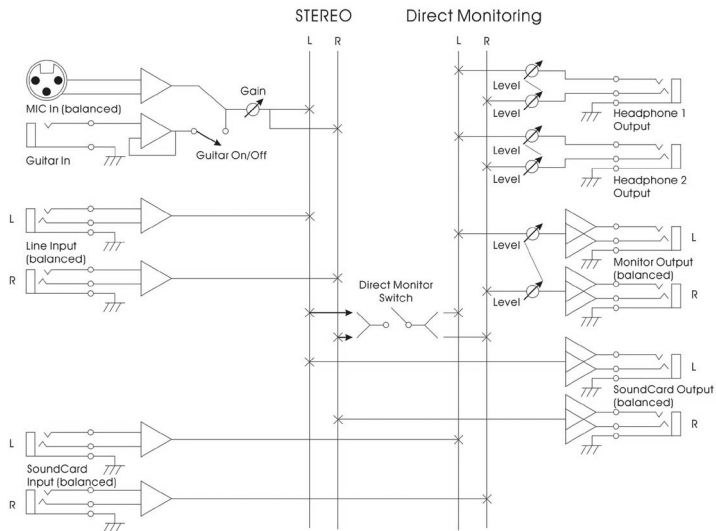

---

## **EXAMPLES OF MATRIX X USAGE**

Matrix X features various input and output connectors to use either in stand-alone mode or used with sound card or external device. It will meet most of your music making, practicing and listening needs. There are some examples of Matrix X usage below to explain how to set up and connect Matrix X to your system. Please refer to them as a quick start guide.

### **1. Stand-alone Mode**

In stand-alone mode, you can use the “Sound Card Input” and “Sound Card Output” in the rear panel to connect external audio equipment .

You should connect “Monitor Output” to a set of active speakers to monitor output sound. You can use the Head Phone 1 in the front panel or Head Phone 2 in the rear panel to monitor, and adjust the output volume via the corresponding control knobs.

#### ***A. Connecting to a synthesizer or electric piano for live performance***

You can use the Matrix X to add high quality microphones with phantom power to a synthesizer with sampling functions or vocal microphone capabilities to any external device with Line Inputs and Outputs (such as many digital pianos).

1. Connect the Line Out of synthesizer to the “Sound Card In” on the rear panel of Matrix X.
2. Connect the “Sound Card Out” on the rear panel of the Matrix X to the Audio In of the synthesizer.
3. Plug a microphone or electric guitar into the “Mic / Guitar In” on the front panel of the Matrix X. Connect an external audio source to the “Line Input” on the rear panel of the Matrix X. This signal could be sampled by a synthesizer with a sampling function or it could simply add a vocal signal to the output of the synth or digital piano.
4. Please press down “Direct Monitor” button for the synthesizer without sampling function.
5. Please adjust the output volume from the sound source or the active speakers. You also can do the same thing by adjusting the “Monitor Vol.” knob.

#### ***B. Listening to music***

1. Connect the Line Out of an external sound source (e.g. DVD player)

- 
- to the “Sound Card In” on the rear panel of the Matrix X.
  2. Press the “Direct Monitor” button down.
  3. Please adjust the output volume from the sound source or active speakers. You can do the same thing by adjusting the “Monitor Vol.” knob.

### ***C. Practicing or playing Electric Guitar / Bass along with music***

1. Connect the Line Out of a sound source (e.g. DVD player) to the “Line Input” on the rear panel of the Matrix X.
2. Connect the electrical guitar (bass) signal to the TS jack of the combo connector on the front panel of the Matrix X. To adjust the gain, turn the “Mic / Guitar In” knob.
3. Press the “Guitar On / Off” button down.
4. Press the “Direct Monitor” button down.
5. Start playing the external sound source and play electrical guitar (bass) along with music.
6. Please adjust music volume on external sound source. The gain of the electric guitar (bass) could be adjusted not only on guitar (bass) but also via the “Mic / Guitar In” knob. Use the “Monitor Vol.” knob to adjust the main output volume.

### ***D. Vocal Practice and Karaoke***

#### **(a) Microphone with self-powered and XLR connector**

1. Connect the Line Out of a sound source (e.g. DVD player) to the “Line Input” on the rear panel of the Matrix X.
2. Connect the microphone to the XLR jack of the combo connector on the front panel of the Matrix X. To adjust the gain, turn the “Mic / Guitar In” knob.
3. Press the “Direct Monitor” button down.
4. Start playing music and enjoying Karaoke.
5. Please adjust the music volume on the external sound source. The gain of microphone can be adjusted via the “Mic / Guitar In” knob. Use the “Monitor Vol.” knob to adjust the main output volume.

#### **(b) Phantom Powered Microphone with XLR connector**

1. Connect the Line Out of sound source (e.g. DVD player) to the “Line Input” on the rear panel of the Matrix X.
2. Connect the microphone to the XLR jack of the combo connector on the front panel of the Matrix X. Adjust the gain by turning the “Mic / Guitar In” knob.

- 
3. Press the “48V On / Off” button down.
  4. Press the “Direct Monitor” button down.
  5. Start playing music and enjoying Karaoke.
  6. Please adjust music volume on the external sound source. The gain of microphone can be adjusted via the “Mic / Guitar In” knob. Use the “Monitor Vol.” knob to adjust the main output volume.

**(c) Microphone with TS connector**

1. Connect the Line Out of the sound source (e.g. DVD player) to the “Line Input” on the rear panel of the Matrix X.
2. Connect the microphone to the TS jack of the combo connector on the front panel of the Matrix X. Adjust the gain by turning the “Mic / Guitar In” knob.
3. Press the “48V On / Off” button down.
4. Press the “Direct Monitor” button down..
5. Start playing music and enjoying Karaoke.
6. Please adjust music volume on the external sound source. The gain of microphone can be adjusted via the “Mic / Guitar In” knob. Use the “Monitor Vol.” knob to adjust the main output volume.

## **2. Working together with sound card**

In Hard-disk Recording mode, “Sound Card In” and “Sound Card Out” in the rear panel of Matrix X have to be connected to “Line Out” and “Line In” ports of Sound card. All other connections are the same as stand-alone mode. In this mode, we recommend not using “Direct Monitor” to avoid latency problems. All of the input and output signal monitoring will be done by hardware mixing of Matrix X.

### ***A. Recording from the Line In***

1. Connect the Line Out of the sound source (e.g. DVD player) to the “Line Input” on the rear panel of Matrix X.
2. Set the recording device driver in the recording software.
3. Playback music and record using the software.
4. Use the input gain slider bar on the sound card’s control panel to set the input signal gain.

### ***B. Recording from a microphone***

**(a) Self-powered Microphone with XLR connector**

1. Connect the microphone to the XLR jack of the combo connector

---

on the front panel of the Matrix X. Adjust the gain by turning the “Mic / Guitar In” knob.

2. Set the recording device driver in the recording software.
3. Pick-up the audio signal from the microphone and start recording in the software.
4. Use the input gain slider bar in the sound card’s control panel or “Mic / Guitar In” knob of Matrix X to set the microphone input signal gain to the software.

**(b) Phantom power Microphone with XLR connector**

1. Connect the microphone to the XLR jack of the combo connector on the front panel of the Matrix X. Adjust the gain by turning “Mic / Guitar In” knob.
2. Press the “48V On / Off” button down.
3. Set the recording device driver in the recording software.
4. Pick-up the audio signal from the microphone and start recording in the software.
5. Use the input gain slider bar in the sound card’s control panel or adjust the “Mic / Guitar In” knob of the Matrix X to set the microphone input signal gain.

**(c) Microphone with TS connector**

1. Connect the microphone to the TS jack of the combo connector on the front panel of the Matrix X. Adjust the gain by turning the “Mic / Guitar In” knob.
2. Press “Guitar On / Off” button down.
3. Set the recording device driver in the recording software.
4. Pick-up the audio signal from the microphone and start recording in the software.
5. Use the input gain slider bar in the sound card’s control panel or the “Mic / Guitar In” knob of the Matrix X to set the microphone input signal gain.

***C. Recording an Electric guitar (or bass)***

1. Connect the electric guitar (or bass) to the TS jack of the combo connector on the front panel of the Matrix X. Adjust the gain by turning the “Mic / Guitar In” knob.
2. Press the “Guitar On / Off” button down.
3. Play the electric guitar (bass) and start recording in the software.
4. The gain of the electric guitar (bass) can be adjusted not only on the guitar (bass) but also via the “Mic / Guitar In” knob, or you can do the same thing using the input gain slider bar in the sound card’s control panel.

## MATRIX X SETTING CHART

Mode	Usage	48V On / Off	Guitar On / Off	Direct Monitor	
Stand-alone	Listen to music	X	X	O	
	Practice or play Electrical Guitar / Bass along with music	X	O	O	
	Karaoke	Microphone with self- powered and XLR connector	X	X	O
		Microphone with XLR connector but without self- powered	O	X	O
		Microphone with TS connector	X	O	O
With sound card	Record from Line In	X	X	X	
	Record from microphone	Microphone with self- powered and XLR connector	X	X	X
		Microphone with XLR connector but without self- powered	O	X	X
		Microphone with TS connector	X	O	X
	Record from Electrical guitar (bass)	X	O	X	

O : Button pressed down

X :Button released

## SPECIFICATIONS

- ⊙ Stereo “Sound Card Input” for connecting with output of sound card (2 balanced, 1/4” TRS)
- ⊙ Stereo “Sound Card Output” for sending signals to Line In of sound card (2 balanced, 1/4” TRS)
- ⊙ Stereo “Line Input” to receive external line level signal (2 balanced, 1/4” TRS)
- ⊙ Stereo “Monitor Output” with volume control for connecting active speakers (2 balanced, 1/4” TRS)
- ⊙ 2 Stereo headphone outputs with independent volume control (1/4” stereo TRS)
- ⊙ 1 “Mic / Guitar In”, with a XLR and TS combo connector that microphone and electric guitar/bass share and a gain control knob
- ⊙ XLR of combo connector is balanced, TS is un-balanced
- ⊙ 2 input signal LEDs (blue, one for each channel), indicate if there is any signal available at the input channel
- ⊙ 2 input peak LEDs (red, one for each channel), indicate if an input signal is near distortion

- ⊙ 48V phantom power with switch (press button), provides power to XLR only
- ⊙ 1 phantom power LED (green) indicates the status of phantom power supply
- ⊙ 1 “Direct Monitor” button toggles the input signal between direct monitoring of the input or the sound card output.
- ⊙ 1 “Guitar On / Off” button turns on “Mic / Guitar In” function in front panel

## **MATRIX X TECHNICAL INFORMATION**

• Number of Input Channels	5
• Number of Output Channels	4
• Number of Headphone Outputs	2
<b>Performance</b>	
• THD + Noise	-102dBr
• Noise Floor (A-weighted)	<10uVrms
• Dynamic Range (A-weighted)	-106dBr
<b>Input</b>	
• Connectors (guitar and microphone)	XLR/TRS combo
• Connectors (sound card input and line input)	1/4” TRS
• Input Impedance, XLR	10K Ohm
• Input Impedance, High Z (1/4”)	1.5M Ohm
• Input Impedance, Line level TRS	10K Ohm
<b>Output</b>	
• Connectors (sound card output and line output)	1/4” TS
• Connectors (headphone)	1/4” TRS
• Output Impedance (line level)	33 Ohm
• Output Impedance (headphone)	<10 Ohm
<b>Front Panel Controls</b>	
• Gain	+8dB
• Headphone volume control	+8dB
• Pad (48V On / Off)	Switch on / off
• Pad (Guitar On / Off)	Switch on / off
• Pad (Direct Monitor)	Switch on / off
<b>Power Supply</b>	
• Type	Linear supply
• Input	15 VAC / 1000mA
• Power	15 Watts
<b>Physical</b>	
• Dimensions	14.5cm x15.5cm x4.3cm

Specifications and appearance are subject to change without notice.

**CME**